



Réglage variable pour les 2 vitesses.
Variable speed setting for the 2 gears.
Variabele instelling voor de 2 snelheden.





Minuterie programmable.
 Programmable timer.
 Programmeerbare timer.

Option:
grille de sécurité.
 Option:
safety grid.
 Optie:
veiligheidsrooster.

Rotation inverse et 10 réglages variables pour les 2 vitesses.
 Reverse direction and 10 variable settings for the 2 gears.
 Omgekeerde draairichting en 10 variabele instellingen voor de 2 snelheden.

Commande digitale.
 Digital control.
 Digitale bediening.

Monté sur roulettes, facile à déplacer.
 Mounted on castors, easily movable.
 Gemonteerd op wieltjes, makkelijk te verplaatsen.

Entrainement courroie.
 Belt drive.
 Riemaandrijving.

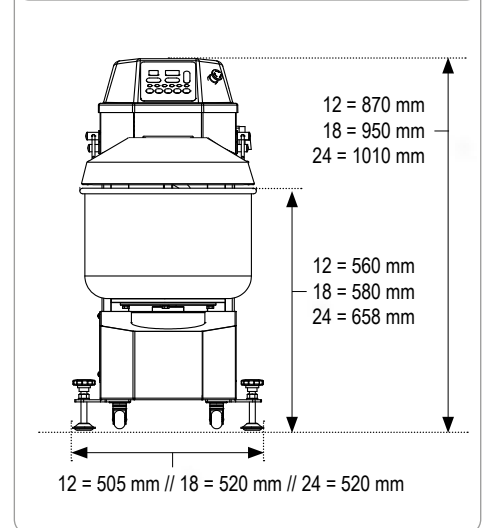
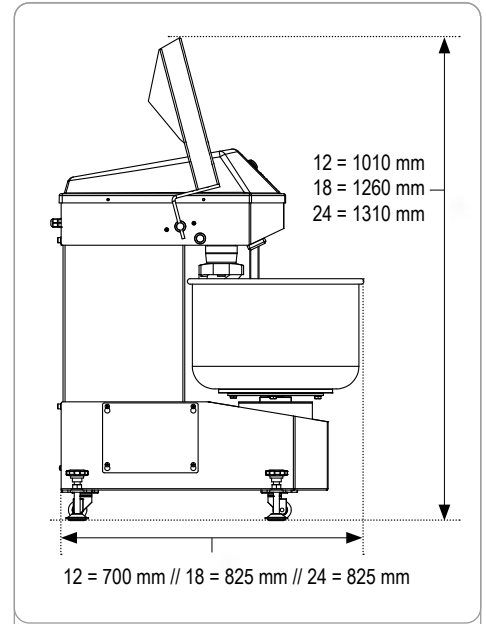

	12	18	24
Capacité pâte Dough capacity Deegcapaciteit	1,5 - 12 kg	2,5 - 18 kg	3 - 24 kg
Capacité farine Flour capacity Bloemcapaciteit	1 - 8 kg	1,5 - 12 kg	2 - 16 kg
Coulage Liquid Vloeistof	0,5 - 4 L	0,75 - 6 L	1 - 8 L
Puissance moteur Motor power Motorvermogen	1,3 kW	1,8 kW	2,2 kW
Trs/min variable Variable R.P.M. Variabele omw/min			65 - 320
Spirale Spiral Spiraal			6,5 - 32
Cuve Bowl Kuip			
Poids net machine Net weight machine Nettogewicht machine	105 kg	130 kg	145 kg
Voltage Voltage Spanning	230V 50Hz 1Ph		